



Operator's Manual

SNOW THROWER ATTACHMENT

For Cub Cadet Series 3000 Tractors

NOTE:

Front Hitch System Model No. 190-343-100
Must be Installed on Tractor.

INSTALLATION AND MAINTENANCE INSTRUCTIONS

Model Number
353

IMPORTANT:

READ SAFETY RULES AND INSTRUCTIONS CAREFULLY

CUB CADET P.O. BOX 368023 CLEVELAND, OHIO 44136-9722 [www.cubcadet.com]

CONTENTS

Section		Page
	Safe Operation	2
	To The Owner	5
I	Introduction	6
II	Assembly, Installation and Removal	8
III	Adjustments and Operation	11
IV	Maintenance	14
	Warranty	16

IMPORTANT

SAFE OPERATION PRACTICES



THIS SYMBOL POINTS OUT IMPORTANT SAFETY INSTRUCTIONS WHICH, IF NOT FOLLOWED, COULD ENDANGER THE PERSONAL SAFETY AND/OR PROPERTY OF YOURSELF AND OTHERS. READ AND FOLLOW ALL INSTRUCTIONS IN THIS MANUAL BEFORE ATTEMPTING TO OPERATE YOUR UNIT. FAILURE TO COMPLY WITH THESE INSTRUCTIONS MAY RESULT IN PERSONAL INJURY. WHEN YOU SEE THIS SYMBOL—  **HEED ITS WARNING.**



WARNING

To reduce the potential for any injury, comply with the following safety instructions. Failure to comply with the instructions may result in personal injury.

SAFE OPERATION PRACTICES FOR SNOW THROWERS

TRAINING

1. Read this owner's manual carefully. Be thoroughly familiar with the controls and proper use of the equipment. Know how to stop the unit and disengage the controls quickly.
2. Never allow children to operate equipment. Never allow adults to operate equipment without proper instructions.
3. No one should operate the unit while intoxicated or while taking medication that impairs the senses or reactions.
4. Keep the area of operation clear of all persons, especially small children and pets.
5. Exercise caution to avoid slipping or falling when mounting or dismounting the tractor.

PREPARATION

1. Thoroughly inspect the area where the equipment is to be used and remove all door mats, sleds, boards, wires and other foreign objects.
2. Disengage all clutches and shift into neutral before starting the engine.
3. Do not operate equipment without wearing adequate winter outer garments. Do not wear jewelry, long scarfs or other loose clothing which could become entangled in the moving parts of the machine. Wear footwear which will improve footing on slippery surfaces.
4. Check the fuel before starting the engine. Gasoline is an extremely flammable fuel. Always use an approved fuel container to store gasoline. Do not fill

the fuel tank indoors while the engine is running or while the engine is still hot. Replace the gasoline cap securely and wipe off any spilled gasoline before starting the engine. An ignition spark or heat may ignite spilled fuel, causing a fire or explosion.

5. Adjust the collector housing height to clear gravel or crushed rock surfaces.
6. Never attempt to make any adjustments while the engine is running (except where specifically recommended by the manufacturer).
7. Let the engine and machine adjust to the outdoor temperature before starting to clear snow.
8. Always wear safety glasses or eye shields during operation, or while performing an adjustment or repair, to protect eyes from foreign objects that may be thrown from the machine in any direction.

OPERATION

1. Do not put hands or feet near rotating parts. Keep clear of the discharge opening at all times.
2. Exercise extreme caution when operating on, or crossing, gravel drives, walks or roads. Stay alert for hidden hazards or traffic. Do not carry passengers.
3. After striking a foreign object, disengage the PTO, stop the engine, remove the wire(s) from the spark plug(s), and thoroughly inspect the snow thrower for any damage. Repair the damage before restarting and operating the snow thrower.
4. If the snow thrower should start to vibrate abnormally, disengage the PTO, stop the engine and check immediately for the causes. Vibration is generally a warning sign of trouble.
5. Disengage the PTO and stop the engine whenever you leave the operating position, before unclogging the collector/impeller housing or discharge chute, and before making any repairs, adjustments or inspections.
6. Never place your hand in the discharge or collector openings. Use a stick or wooden broom handle to unclog the discharge opening.
7. Take all possible precautions when leaving the unit unattended. Disengage the collector/impeller, shift into neutral and engage the parking brake, stop the engine and remove the key.
8. When cleaning, repairing or inspecting, make certain the collector/impeller and all moving parts

have stopped completely. Disconnect the spark plug wire and keep it away from plug to prevent accidental starting.

9. **Do not run the engine indoors** except when starting the engine and transporting the snow thrower in or out of the building. Open doors prior to starting engine. Exhaust gases contain carbon monoxide and are extremely dangerous.
10. Do not clear snow across the face of slopes. Exercise extreme caution when changing direction on slopes. Do not attempt to clear steep slopes.
11. Never operate snow thrower without all guards, plates or other safety protection devices in place.
12. Never operate the snow thrower near glass enclosures, automobiles, window wells, a drop off, etc., without proper adjustments of the snow thrower discharge angle. Keep children and pets away.
13. Do not overload the machine capacity by attempting to clear snow at too fast a rate.
14. Never operate the machine at high transport speeds on slippery surfaces. Look behind and use care when backing up.
15. Never direct discharge at bystanders or allow anyone in front of the unit.
16. Disengage power to the collector/impeller when transporting or not in use.
17. Use only attachments and accessories approved by the manufacturer of snow thrower (such as wheel weights, counterweights, cabs, etc.).
18. Never operate the snow thrower without good visibility or artificial light.

MAINTENANCE AND STORAGE

1. Check for proper tightness of shear bolts, mounting bolts, etc., at frequent intervals to be sure equipment is in safe working condition.
2. Never store the machine, with fuel in the fuel tank, inside a building where ignition sources are present, such as hot water and space heaters, clothes dryers and the like. Allow the engine to cool before storing in any enclosure.
3. Always refer to the Owner's Manual instructions for important details if the snow thrower is to be stored for an extended period.
4. Run the machine for a few minutes after throwing snow to prevent freeze up of the collector/impeller.

PRODUCT SAFETY GRAPHICS

1. Keep safety product graphics (decals) clean.
2. Replace any safety graphic that is damaged, destroyed, missing, painted over or can no longer be read.
3. Replacement safety graphics are available through your Cub Cadet dealer.



ON TOP OF DISCHARGE CHUTE



**ON UPPER/REAR OF BLOWER HOUSING
DANGER W/SCRIPT — FACING OPERATOR
DANGER W/GRAPHIC — FACING FRONT OF SNOW THROWER**

TO THE OWNER

The Cub Cadet 45-inch Snow Thrower Attachment, Model Number 353, is designed for use on Cub Cadet Series 3000 Tractors. Contained in this manual are instructions for the installation and use of the snow thrower assembly with these tractors.

Please keep this manual. The instructions in this manual explain the minor assembly required; installation and seasonal removal; and the adjustment, operating and maintenance procedures for the snow thrower assembly. Read this manual carefully to familiarize yourself with the equipment before you install and operate the snow thrower.

The Front Hitch System, Model 190-343-100, MUST be installed on the tractor to allow installation of the Snow Thrower Attachment.

The Hydraulic Angling Kit accessory, Model 190-288-100, for the Front Hitch System SHOULD NOT be used with the Snow Thrower Attachment. Accidental activation of the angling system could cause damage to both the snow thrower and tractor.

Read and observe all WARNING and CAUTION statements. They are included to provide for the protection of the equipment installer and user, and to ensure prolonged service life of the equipment.



WARNING

To increase traction and stability of the tractor when using the snow thrower attachment, it is recommended that rear wheel weights, or the rear weight bracket with a minimum of three suitcase weights, be installed on the tractor. The Rear Wheel Weight Kit is available through your Cub Cadet dealer by ordering kit number 190-412. The Rear Weight Bracket Kit is available as kit number 190-413, which includes **only** the bracket and mounting hardware. The individual suitcase weights can be ordered under part number 759-3389.

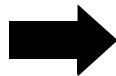

NOTE

References to LEFT and RIGHT indicate the left and right sides of the tractor when facing forward in the driver's seat, unless specifically instructed to reference from a different position on the tractor. Reference to the FRONT indicates the grille end of the tractor; to the REAR indicates the draw bar end.

SECTION I. INTRODUCTION

This section will help you to become familiar with the components of the 45" Snow Thrower Attachment, Model 353.

Select a firm level surface that is large enough to accommodate both the snow thrower assembly and the tractor w/ front hitch assembly. After removing the upper crating material, remove the hardware pack and carefully roll the snow thrower assembly rearward so that it rests on its bottom. *When repositioning the snow thrower, use care not to pinch or bind the chute crank support tube (D, Figure 1).* Cut the tie strap(s) and remove any packaging material from the chute crank rod/tilt handle/support tube assembly (C thru E, Figure 1), then position to the *left* side of the snowthrower assembly. Refer to Figures 1 and 2 to confirm that all parts are present and to acquaint yourself with the part descriptions. Throughout the instructions in this manual the parts shown in Figures 1 and 2 will be identified by name, followed by either their callout letter or number in parenthesis.

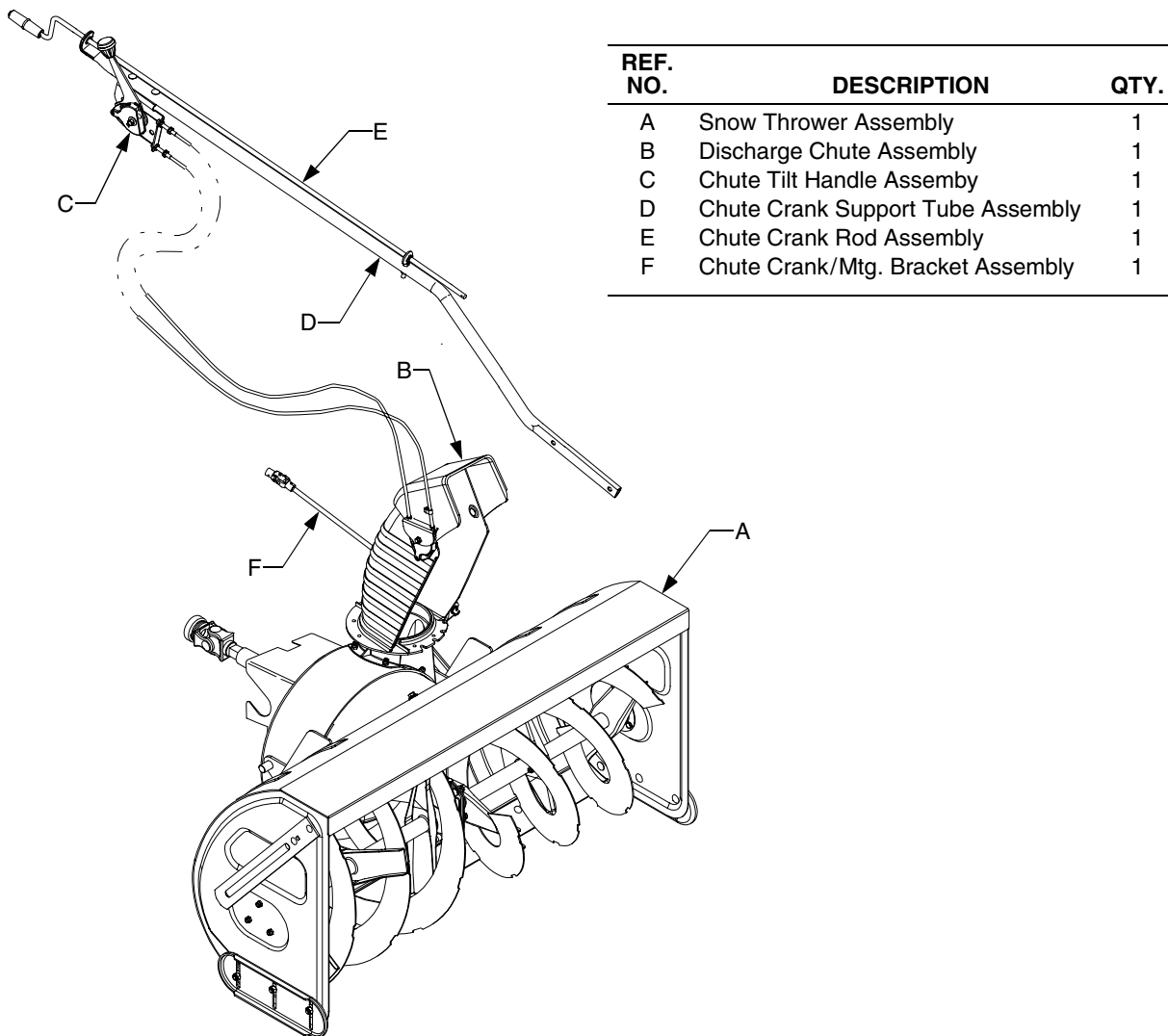
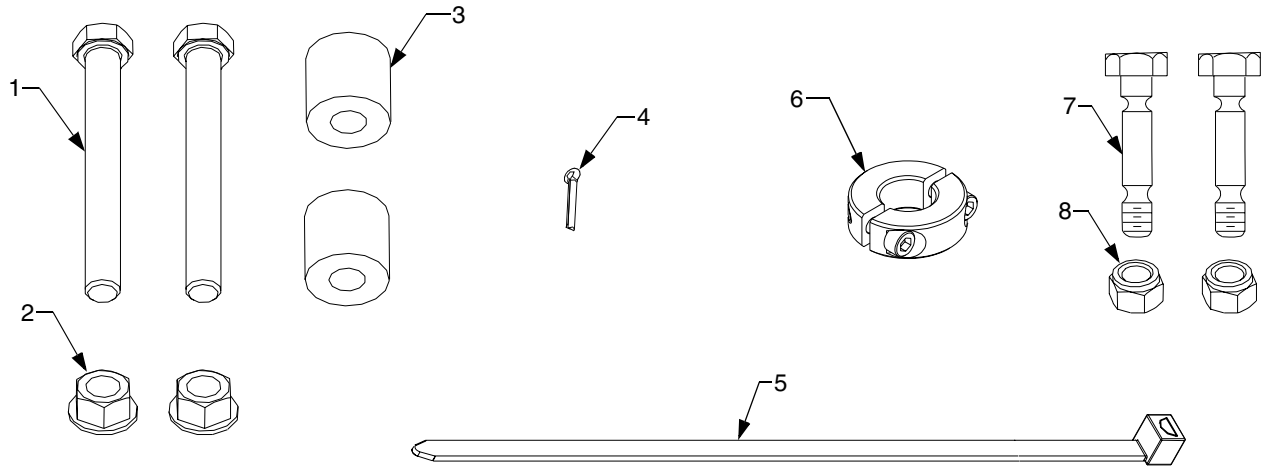

Figure 1

CONTENTS OF HARDWARE PACK



REF. NO.	PART NUMBER	DESCRIPTION	QTY.
1	710-3022	Hex Cap Screw, 3/8-16 X 2.75 Lg GR5	2
2	712-0431	Hex Flange Lock Nut, 3/8-16	2
3	750-0748	Spacer, 3/8 ID x 1.0 OD x 1.25 Lg	2
4	714-0507	Cotter Pin, 3/32 X 3/4 Lg	1
5	725-0157	Cable Tie	1
6	711-1351	Split Locking Collar Assembly	1
7	710-0891	Shear Bolt, 5/16-18 X 1-3/4 Lg (Extra)	2
8	712-0429	Hex Insert Lock Nut, 5/16-18 (Extra)	2

Figure 2

SECTION II. ASSEMBLY, INSTALLATION AND REMOVAL.

This section contains instructions for final assembly of the 45" Snow Thrower, and the quick attachment steps for installation and removal of the snow thrower. Before beginning, select a firm and level surface large enough to accommodate both the snow thrower attachment and tractor.

The mower deck and its front lift bracket assembly should be removed from the tractor before installing the snow thrower. Refer to the mower deck Operator's Manual for deck removal instructions. To remove (or install) the front lift bracket assembly while the Front Hitch Kit Assembly is installed, proceed as follows:



WARNING

If the tractor has been recently operated, the muffler, exhaust pipe, and surrounding areas will be HOT. Allow the tractor to cool before beginning installation.

- Loosen the hex lock nut (or wingnut knob) securing the pivot pin on the *left* side of front hitch.
- Remove the hex lock nut (or wingnut knob) and pivot pin from the *right* side of the front hitch. Lower the *right* side of the hitch pivot plate assembly.
- Push downward on the tractor's quick attach rod and remove the deck front lift bracket assembly.
- Reposition the hitch pivot plate and install the RH pivot pin and hex lock nut (wing nut). Tighten the *left* hex lock nut. Refer to the Front Hitch Operator's Manual if necessary.

A. SNOW THROWER ASSEMBLY.

1. Insert the two hex cap screws (1) through the holes at the forward end of the chute crank support assembly (D), then slide a spacer (3) onto each cap screw (1). See Figure 3.

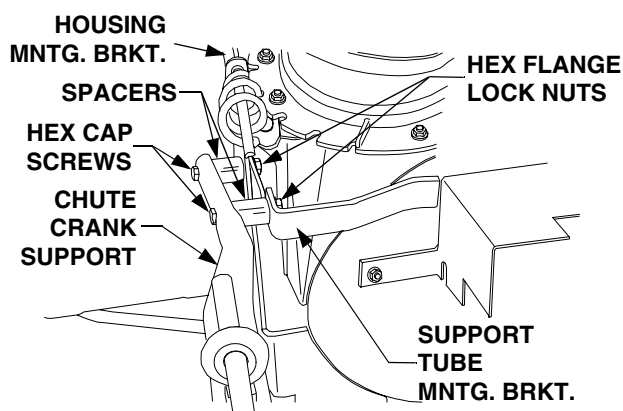

Figure 3

2. Position the chute crank support tube (D) to insert the screws (1) into the holes of the support tube mntg. bracket and the housing mntg. bracket on the left rear of the snow thrower housing. Secure with the hex flange lock nuts (2). Refer to Figure 3.
3. Secure the tilt handle cables (C) to the inside of the support tube (D) with the cable tie (5). See Figure 4. Cut excess length from the cable tie.

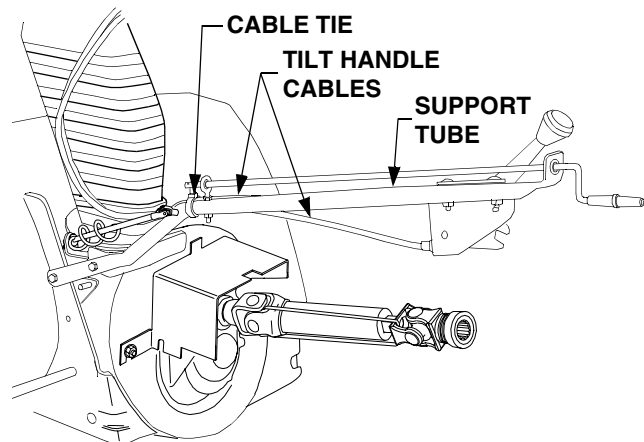

Figure 4

4. After making sure the chute crank rod is routed through the eye bolt, insert the rod (E) into the sleeve of the joint block on the chute crank assembly (F). Align the holes and secure the rod with the cotter pin (4). See Figure 5.

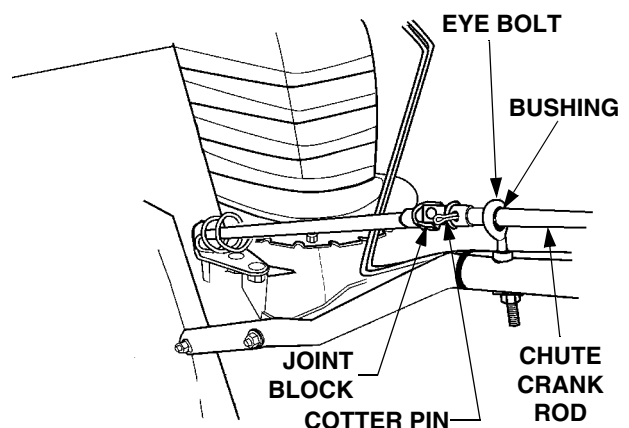

Figure 5

5. Remove the two socket hd. screws from the split locking collar assembly (6) and install the collar onto the bottom of the piston of the front hitch lift cylinder. Secure with the two socket hd. screws (See Figure 6). *NOTE: If necessary, use the tractor hydraulic system to slightly extend the cylinder piston.*

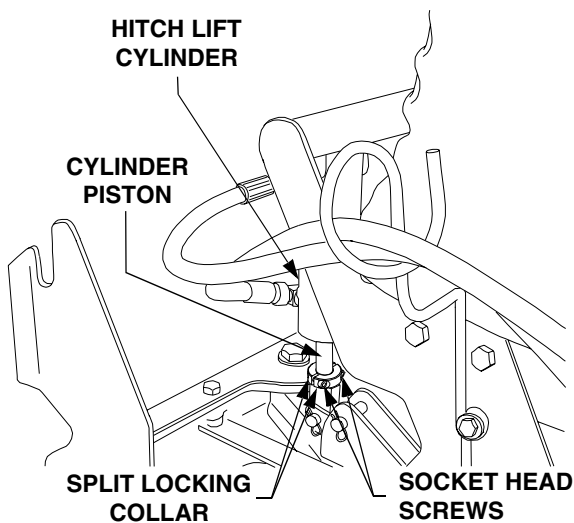

Figure 6

B. INSTALLATION.

NOTE

If the Hydraulic Angling Kit (190-288-100) is installed on the front hitch, accidental actuation of the angling system could result in damage to the snow thrower and/or tractor. Whenever the snow thrower is installed, it is recommended that the angling cylinder be removed and replaced by either the standard front hitch strut (See Figure 8) or the manual angling kit (190-171), set in the center position. The following step 1 applies *ONLY* to units equipped with the hydraulic angling kit.

1. Remove the angling cylinder as follows:
 - a. Compress the locking collars of the female fittings to disconnect the angling cylinder hoses from the coupling assemblies on the left side of the tractor.
 - b. Remove the hoses from the hose support rod.
 - c. Remove the internal cotter pins and clevis pins fastening the angling cylinder to the pivot plate and the front hitch yoke.

- d. Install the front hitch strut (or manual angler-set in center position) with the clevis pins and internal cotter pins. Refer to the Angling Kit Operator's Manual if necessary.

2. Cut the cable tie holding the two halves of the drive shaft together and slide the male half from the female half (See Figure 7).
3. Pivot the female half shaft to the *right* and place in the slot in the *right* side of the shaft cover (See Figure 7).

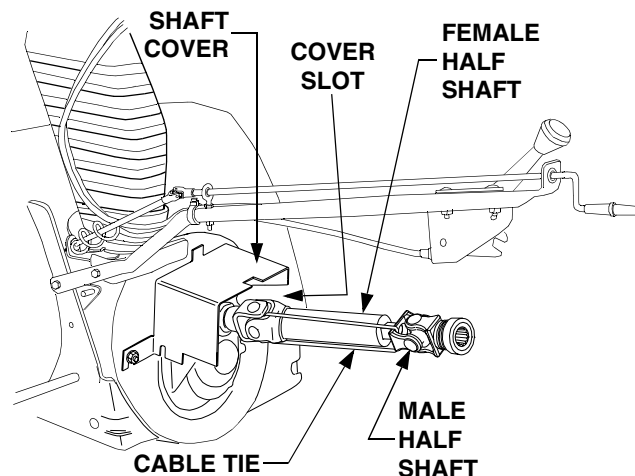

Figure 7

4. Make certain the support pins at the bottom of the front hitch yoke are in the engaged position (through holes in yoke). See Figure 8.

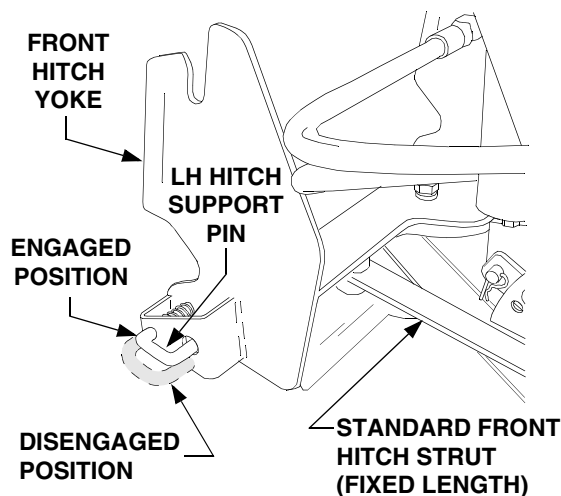

Figure 8

5. Start the tractor and align the front hitch yoke with the attachment brackets on each side of the rear blower housing (Refer to Figure 9).
6. Lower the front hitch yoke to clear the bottom of the attachment bracket pins and carefully drive the tractor forward to align the bracket pins with the slots in the hitch yoke (See Figure 9).
7. Using the tractor hydraulic system to raise the front hitch yoke, slowly lift the snow thrower until the hitch support pins snap into the holes of the LH and RH housing mntg. brackets (See Figure 9).

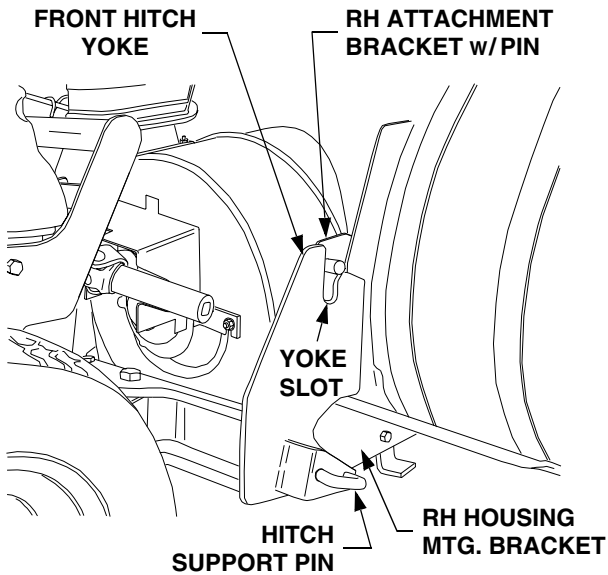

Figure 9

8. Stop the tractor engine and engage the parking brake. Check that support pins are fully engaged in the housing mntg. brackets holes (See Figure 9).



WARNING

If the tractor has been recently operated, the muffler, exhaust pipe, and surrounding areas will be HOT. Allow the tractor to cool before beginning installation.

9. Pivot the female half shaft out of the cover slot and position so that it points rearward between the tractor frame. Refer to Figure 10.

10. Slide the male half shaft into the female half
11. Compress the auto-lok collar on the snow thrower drive shaft; then slide the shaft fully onto the PTO shaft of the tractor and release the auto-lok collar (See Figure 10). The drive shaft will lock onto the PTO shaft if properly connected. *NOTE: It may be necessary to slightly rotate the drive shaft to align the splines of the shafts.*

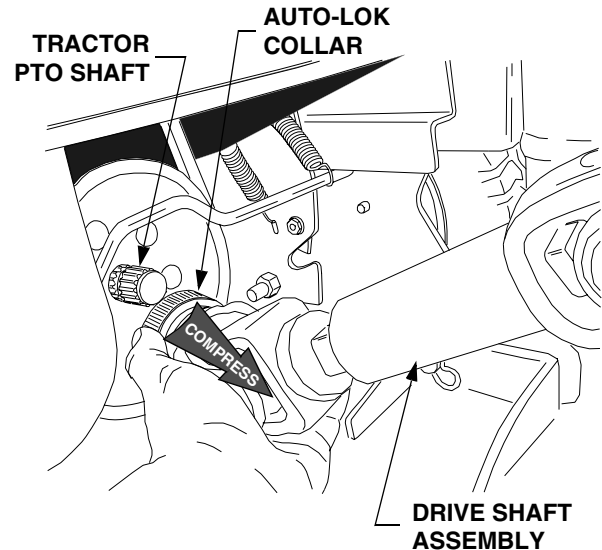

Figure 10

C. REMOVAL.

1. Move the snow thrower to its storage location.
2. Compress the auto-lok collar of the snow thrower drive shaft and disconnect the shaft from the tractor PTO shaft. Refer to Figure 10.
3. Pull the hitch support pins outward and rotate to lock in the disengaged position. Refer to Figure 8.
4. Using the tractor hydraulic system, lower the front hitch yoke to disengage the snow thrower attachment bracket pins from the slots of the hitch yoke (Refer to Figure 9).
5. Back the tractor away from the snow thrower.

SECTION III. ADJUSTMENTS AND OPERATION

A. ADJUSTMENTS



WARNING

If the snow thrower is to be used on gravel surfaces, use **extreme** caution to avoid picking up gravel with the shave plate or auger. Loose gravel can damage the auger or housing, and could be thrown at high speed by the impeller—causing possible injury to bystanders or damage to surrounding objects.

1. Skid Shoe Adjustment

The skid shoes are mounted on each side of the auger housing. They determine the distance the shave plate is raised above the plowing surface. The shave plate should be high for a gravel driveway or other uneven surfaces and low for paved surfaces. Adjust the skid shoes as follows:

- Raise the snow thrower assembly off the ground and place a block under each end of the shave plate.
- Loosen the hex insert lock nuts and bell washers securing the skid shoes to the housing.
- Move the skid shoes up or down to the desired position and securely tighten the lock nuts. Adjust both skid shoes to the same height. Refer to Figure 11. Remove the blocks.

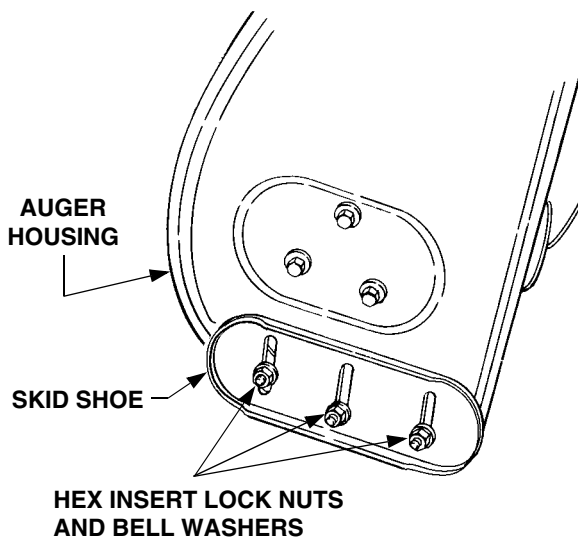

Figure 11

2. Drift Cutters

Drift cutters on both sides of the auger housing can be adjusted to the up position for a higher cut. Refer to Figure 12 and proceed as follows:

- Remove each drift cutter by removing the two carriage bolts and hex insert lock nuts.
- Turn the drift cutters to the up position and secure with the carriage bolts and lock nuts as shown in Figure 12.

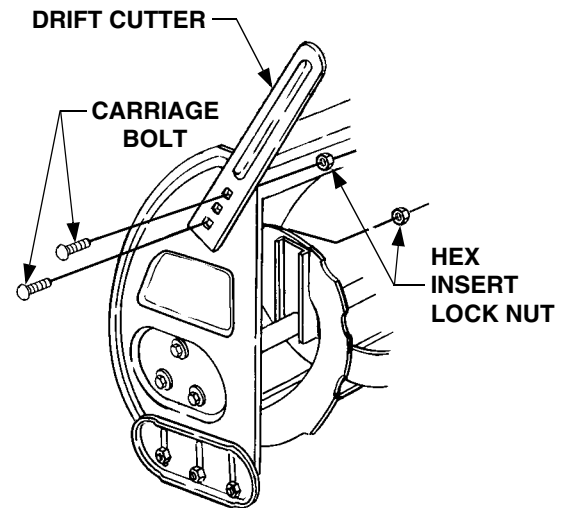

Figure 12

B. CONTROLS

The thrower controls are conveniently located to be operated from the operator's position on the tractor.

1. Lift Lever

The tractor hydraulics and front hitch system are used to raise or lower the snow thrower. If installed as recommended, the inner lift handle should control the front hitch system. Pull the lift handle upward (rearward) to raise the snow thrower. Push the lift lever downward (forward) to lower the snow thrower to the ground.

2. Front Power Take-Off (PTO)

The tractor front PTO switch controls engagement of the snow thrower. To engage the auger, pull the PTO switch handle upward. Push the PTO switch handle downward to disengage the PTO and stop the snow thrower auger.

3. Discharge Chute Control Crank

The discharge chute control crank is located on the left hand side of the snow thrower. The chute crank controls the direction in which the snow is thrown. The discharge radius is 190 degrees. Turn the crank clockwise to rotate the discharge chute opening toward the left, and counterclockwise to rotate toward the right. Refer to Figure 13.

4. Chute Tilt Handle

The chute tilt handle assembly is also located on the left hand side of the snow thrower assembly. The upper chute of the discharge chute assembly pivots downward when the tilt handle is pushed forward, decreasing the distance snow is thrown. Pulling the handle backwards pivots the upper chute upward, increasing the distance snow is thrown. Refer to Figure 13.

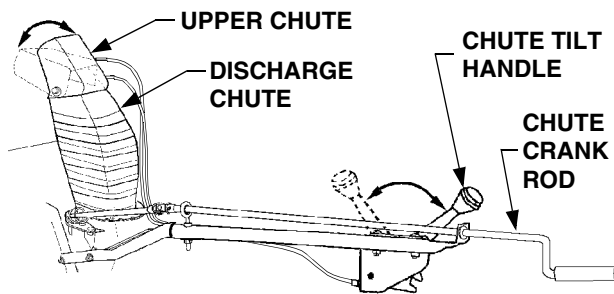

Figure 13

C. OPERATION

The following steps describe methods for safe and proper operation of this snow thrower. Refer to "SAFE OPERATION PRACTICES" on page 2 of this manual for additional safe operating practices.

1. The snow thrower is capable of handling heavy snow conditions. Become fully familiar with all aspects of both the tractor and snow thrower prior to its usage. **DO NOT** remove any guards or covers while operating the tractor and snow thrower.



WARNING

Whenever the snow thrower is installed on the front of the tractor, usage of rear weights on the tractor is recommended to counterbalance the weight of the snow thrower and provide stability to the tractor. See "TO THE OWNER" on page 5.

2. Before placing the snow thrower into operation:
 - a. Check **all** nuts and bolts for proper tightness. Be sure that all parts are properly assembled.
 - b. Test **all** controls for smooth and proper operation.
 - Tractor lift handle and front hitch system
 - PTO switch
 - Discharge chute control crank assembly
 - Discharge chute tilt control
 - c. Inspect the tractor and snow thrower to make certain both are in good operating condition.
 - d. Fill the tractor's fuel tank outdoors. Avoid spilling fuel onto the engine or any other source of heat or combustion. **Do not** fill the tank while the engine is running. Wipe up any spilled fuel before starting the engine.
3. The auger speed is directly related to the engine speed. For optimal snow removal and discharge, maintain high engine R.P.M. (full throttle). Control the tractor's ground speed using the *forward* control pedal (and cruise control feature, if desired). It is recommended that the tractor be operated at a slow ground speed for safer handling and efficient snow removal.
4. Snow removal conditions vary greatly from light fluffy snowfall to wet heavy snow. Therefore, operating instructions must be flexible to fit the conditions encountered. The operator must adapt the tractor and snow thrower to the depth of snow, wind direction, temperature and surface conditions.
5. In deep, drifted or banked snow, it will be necessary to use full throttle and a slow ground speed. Drive the auger into the snow, stop and allow the auger to clear the snow. Repeat this method until a path is cleared. On the second pass (and each succeeding pass), overlap the preceding pass enough to allow the auger to handle the volume of snow without having to stop the tractor.
6. In extremely deep snow, the snow thrower may be raised to the transport position, then slowly driven into the deep snow to remove the top layers first. However, do not drive the tractor into a snow bank where the snow has not been cleared to the ground level. Stop the tractor's forward movement and allow the auger to clear the snow. Reverse the tractor and lower the snow thrower to the ground to clear the remaining snow. Working with repeated passes into and out of drifts, even the deepest snow piles can be cleared.

D. SPECIAL PRECAUTIONS



WARNING

If the snow thrower becomes plugged with snow or jammed due to hitting a foreign object, immediately disengage the PTO to stop the snow thrower, then stop the tractor engine. If plugged, SAFELY (see below) clear the chute before resuming operation.



WARNING

Never place your hand into the discharge chute to remove plugged snow. Use a wooden dowel rod, or similar object, to unclog the chute. **Never use your hand to remove any object jamming the auger or impeller.** The auger or impeller could move when the obstruction is dislodged. Use an appropriate tool (dowel rod, bar, etc.) to remove the obstruction.



WARNING

If the auger is jammed or bent from hitting a foreign object, disengage the PTO and stop the tractor engine. Remove the spark plug wires from the spark plugs and then remove the foreign object from the auger. If damage is noted, repair or replace damaged components prior to continuing operation. Reconnect the spark plug wires and resume operation.

E. OPERATING TIPS

- Whenever possible, discharge snow down wind.
- **DO NOT** attempt to clear ice or hard packed-frozen snow.
- Always overlap each pass slightly to assure complete snow removal.
- A frozen or stuck auger or chute must be broken loose or thawed with care. When attempting to loosen a frozen or jammed auger, shut off the tractor engine and disconnect the spark plug wire(s). **Never attempt to clear the snow thrower at any time with the tractor engine running.**



NOTE

When the snow thrower and tractor are not in use, lower the snow thrower to the ground to eliminate the excess weight from the lift system and the front tires.



WARNING

When making any adjustments, disengage the PTO and turn the tractor engine off.

SECTION IV. MAINTENANCE

Section IV describes maintenance procedures designed to keep your snow thrower in good operating condition.

SHAVE PLATE AND SKID SHOES

The shave plate and skid shoes on the bottom of the snow thrower housing are subject to wear. They should be periodically checked for wear and replaced when necessary. Failure to do so will result in damage to the housing.

1. Replace the shave plate as follows:
 - a. Remove the seven carriage bolts and hex flange lock nuts that secure the shave plate to the bottom of the housing.
 - b. Remove the rear most carriage bolt, bell washer and hex insert lock nut securing the back end of each skid shoe to the sides of the housing.

NOTE

If necessary to ease sliding the shave plate out of position on the housing, *loosen* the four remaining hex insert lock nuts which secure the skid shoes to the housing.

- c. Slide the shave plate out of the off-set slot of the housing, and from between the skid shoes and side panels of the housing.
 - d. With the mounting holes toward the back, slide the new shave plate into position and secure with the fasteners removed previously.
2. The skid shoes are reversible for longer life. Remove the carriage bolts, bell washers and hex insert lock nuts fastening the skid shoes to the housing. Turn the shoes over and/or reverse sides to ensure even wear and extend their service life.

AUGERS

1. The augers are secured to the auger shaft with two shear bolts and hex insert lock nuts. Refer to Figure 14. If the auger is suddenly jammed by a foreign object or ice chunk, the bolts are designed to shear — minimizing potential damage to the gear boxes.
2. If the augers will not turn, check the bolts to see if they have sheared. Two replacement shear bolts (7) and hex insert lock nuts (8) have been provided with the snow thrower. For future use, order part number 710-0891 for replacement shear bolts and 712-0429 for the lock nuts.

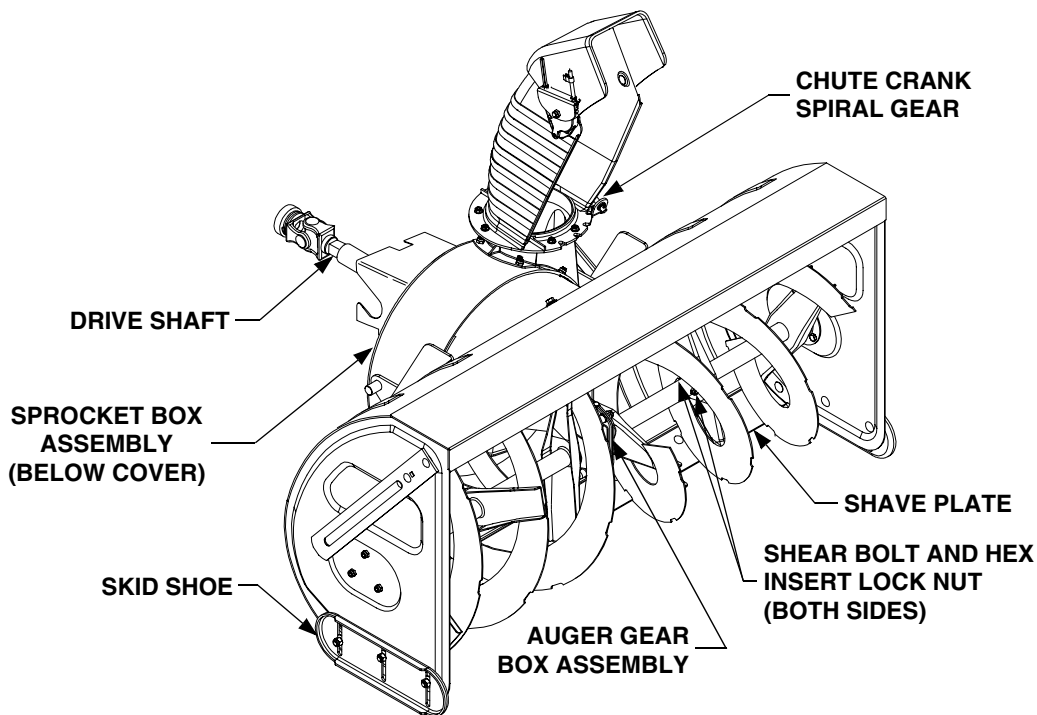

Figure 14

LUBRICATION

1. The auger gear box is lubricated with grease at the factory and is neither externally servicable, nor requires checking. If disassembled for any reason, lubricate with 2.5 ounces (by weight) of Alvania grease, part number 737-0168A. Before reassembling, remove old sealant and apply Loctite Ultra Grey (759-3746) sealant or equivalent.
2. The sprocket box assembly is also neither externally servicable, nor requires checking. If disassembled for any reason, lubricate with 5.0 ounces (by weight) of Benalene grease, part number 737-0300A. Before reassembling, remove old sealant and apply Loctite Ultra Grey (759-3746) sealant or equivalent.
3. Apply penetrating oil to the cables of the chute tilt handle assembly at least once a season.
4. Apply a good grade of spray lubricant to the universal joint of the chute crank, and to the pivot of the chute tilt handle at least once a season.
5. Lubricate the chute crank spiral gear with a multi-purpose automotive grease once a year.
6. Lubricate the telescoping square spindle of the drive shaft (rear half) using 251H EP grease or an equivalent No. 2 multi-purpose lithium grease once a year.
7. Lubricate the bearings at each end of the auger shaft with oil or spray lubricant at least once a season.
8. Although not required, it is advisable to remove the auger shear bolts at least once a season and spray penetrating oil, or similar lubricant, between the auger tubes and auger shaft.

OFF-SEASON STORAGE

At the end of the snow season the following steps are recommended:

1. Remove the snow thrower assembly from the tractor.
2. Wash off any salt deposits which may have dried on the snow thrower housing. Paint, or cover with a light coat of oil, any exposed metal surfaces.
3. Lubricate bearings and pivot points with a good grade of spray lubricant.
4. Store the snow thrower in a dry place.

MANUFACTURER'S LIMITED WARRANTY FOR:



TWO-YEAR RESIDENTIAL ONE-YEAR COMMERCIAL

Proper maintenance of your Cub Cadet equipment is the owner's responsibility. Follow the instructions in your operator's manual for correct lubricants and maintenance schedule. Your Cub Cadet dealer carries a complete line of quality lubricants and filters for your equipment's engine, transmission, chassis and attachments.

Riding mowers, lawn tractors, garden tractors, Cub Cadet attachments and home maintenance products

This limited warranty for residential users, covers any defect in materials or workmanship in your Cub Cadet equipment for two years from the date of purchase for the first user purchaser. We will replace or repair any part or parts without charge through your authorized Cub Cadet dealer.

Batteries have a one-year prorated limited warranty with 100% replacement during the first three months.

V-belts for either the traction drive or any attachments are covered for one year only.

Cub Cadet equipment used commercially is warranted for one year only.

(Commercial use is defined as either having hired operators or used for income producing purposes.)

Items not covered

The warranty does not cover routine maintenance items such as lubricants, filters (oil, fuel, air and hydraulic), cleaning, tune-ups, brake and/or clutch inspection, adjustments made as part of normal maintenance, blade sharpening, set-up, abuse, accidents and normal wear. It does not cover incidental costs such as transporting your equipment to and from the dealer, telephone charges or renting a product temporarily to replace a warranted product.

There is no other express warranty.

How to obtain service

Contact your authorized Cub Cadet servicing dealer who sold you your Cub Cadet equipment. If this dealer is not available, see the Consumer Yellow Pages under "lawn mowers" for the name of a dealer near you.

If you need further assistance in finding an authorized Cub Cadet servicing dealer, contact:

**Cub Cadet Corporation
Post Office Box 368023
Cleveland, Ohio 44136**

How does state law apply?

This limited warranty gives you specific legal rights, and you may also have other rights which vary from state to state.